

We Lighten Your Load and Ease Your Burden



Ergo Tranz[®] Compact Transporter

Description

An innovative compact, battery-powered lift/transporter that allows anyone to practically and efficiently transport anything- easier than ever. If the material or object you are moving is too heavy or awkward for a person to lift and carry manually, Ergotech offers the perfect solution. Ergo-Tranz makes any object easy to lift and transport, up to 600 pounds.

Application

Unlimited applications in any industry. Advantageous in any warehouse, shopfloor or work area. Ideal even in narrow and confined spaces. Ergo-Tranz replaces hand trolleys, stackers, winches with a simple and practical solution for every task.

Ergonomic Benefit

- Eliminate employee strain, fatigue and injury.
- Create a safer and more productive work environment.

Standard Features

- Designed and built in the USA for the most robust and heavy-duty applications.
- Light-weight, solid aluminum construction.
- Easily maneuverable in confined spaces and narrow aisles.
- Precision lift screw mechanism for lift position accuracy.
- Smooth, precise and accurate load positioning.
- Lift brake provides accurate positioning and safe holding with no creep.
- Customized powered or non-powered lift attachments available.
- Hand pendent controls all lift and powered End-Effector functions.
- Available in 220 lbs., 450 lbs. and 600 lbs. load capacities.
- Smart features like variable lift speed between 0 - 6"/sec. for precise positioning.
- Overload protection for operator safety and equipment protection.
- Sleep mode with touch button wake up to extend battery life.
- Heavy duty 24 Volt sealed batteries (18 amp-hours) for many hours of operation between charges.
- Built-in high frequency solid-state universal charger (90-240VAC) with automatic charge cut-off and trickle float that can be left connected indefinitely without harming batteries.
- Battery state-of-charge status display during charging.
- Lift-inhibit prevents operation during battery charging.
- Three-position foot-operated rear brake control system with parking brake, normal swivel or directional steering of rear casters.

Options

- Solid state battery state-of-charge indicator.
- Customized load-handling End-Effectors.
- 3", 4" or 5" Front Casters.
- V-leg configuration to access corners of pallet.
- Electric leg straddle allows the base legs to separate so the unit can easily be maneuvered close to or around objects as well as providing additional stability in various lifting situations.

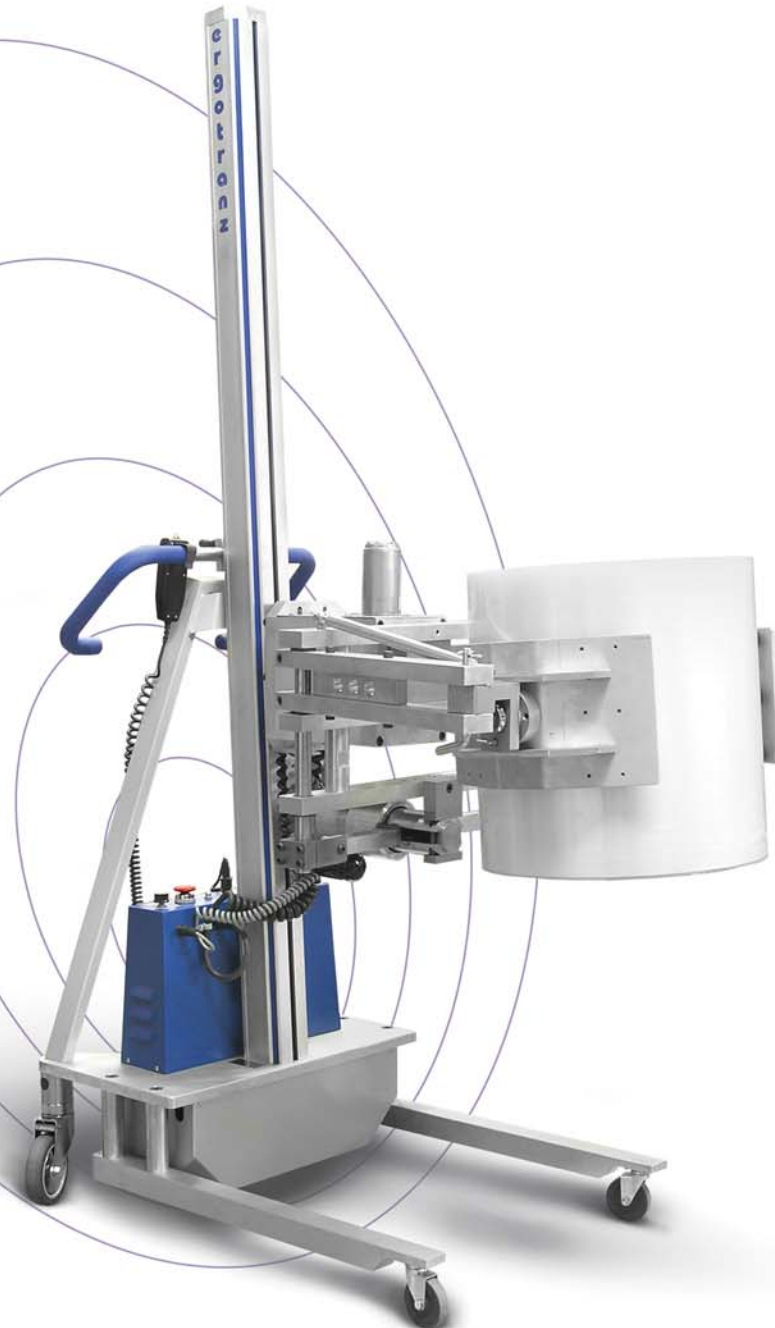

Sample of End Effectors

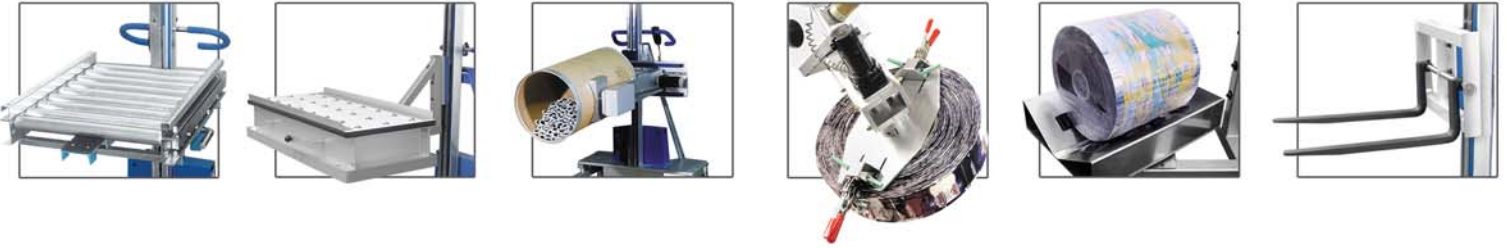

Technical Information

Model	Maximum Load Capacity at 12 L.C.	Standard Front Casters	Leg Height w/ Casters	Leg Width	Outer Leg Base Width	Stroke	Lifting Speed (variable)	Battery Pack Capacity	Weight with Batteries	
ET-220F	220 Lbs.	2"	3¼"	1¾"	24"	Fixed	Floor to 58"	0 - 6" / Sec	24V DC, 18 Ah	165 Lbs.
ET-220V	220 Lbs.	2"	3¼"	1¾"	24" variable to 30"		Floor to 58"	0 - 6" / Sec	24V DC, 18 Ah	180 Lbs.
ET-450F	450 Lbs.	4"	5¼"	1¾"	24"	Fixed	Floor to 58"	0 - 2" / Sec	24V DC, 18 Ah	195 Lbs.
ET-450V	450 Lbs.	4"	5¼"	1¾"	24" variable to 30"		Floor to 58"	0 - 2" / Sec	24V DC, 18 Ah	210 Lbs.
ET-600F	600 Lbs.	4"	5¼"	1¾"	24"	Fixed	Floor to 58"	0 - 2" / Sec	24V DC, 18 Ah	255 Lbs.

