

*The perfect upgrade
from a manual
pallet truck for light
duty applications.*



CAPACITY

- 3,000 lbs.
- 24 volt system

HYDRAULIC/ELECTRIC SYSTEM

- Lift ram is hard chromed plated for long life and mounted for even load lifting
- Pump unit, motor and solenoid actuated, pressure compensated lowering valve is easily accessible
- Programmable 24 volt Curtis transistor controller motor provides smooth and seamless control
- Infinitely variable forward, reverse, drive and brake control
- Automatic neutral braking on throttle release
- Auto reset circuit breaker and fused control circuit designed to protect the electrical system

OPERATION/CONTROLS

- Low profile front end allows for high degree of fork tip visibility
- Thumb throttle, lift, lower, horn and reversing switch are easily located on the ergonomically correct top mount handle
- Key switch, power disconnect and hour/meter battery discharge indicator mounted on dash
- Low effort steering
- Braking activation at top and bottom of handle working range

DRIVE UNIT

- High performance vertically mounted SepEx separately excited motor provides maximum torque throughout entire speed range
- No directional contactors therefore less maintenance. Single line contactor operates with an integrated power disconnect switch
- Long life electromagnetic braking system
- Precision helical drive gears provide quiet operation and transfers power more efficiently from drive motor to axle
- Easy access cover exposes electrical and major mechanical components for inspection and maintenance

OPTIONAL EQUIPMENT

- Consult factory

Specifications

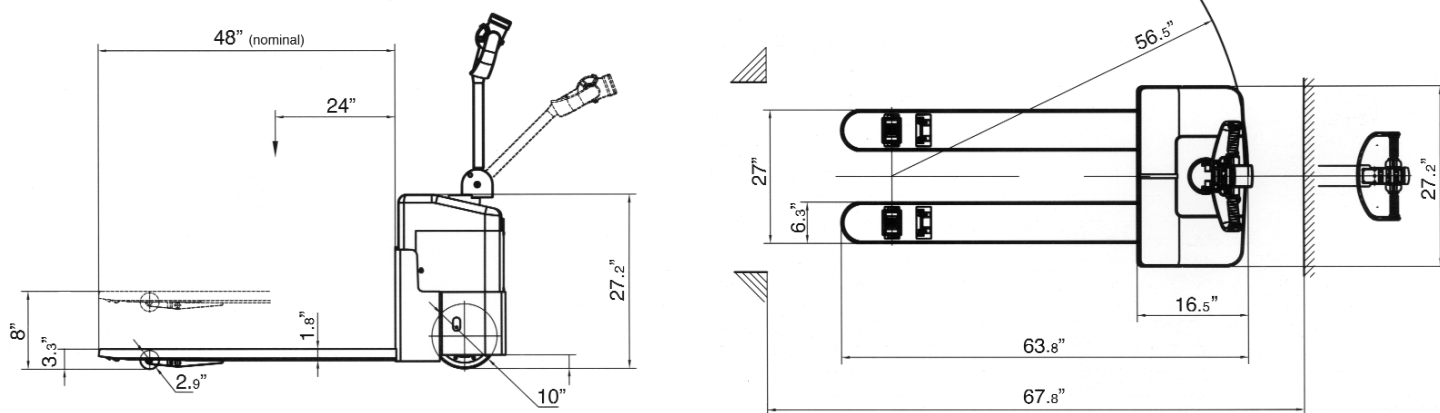

| | MODEL | | XPT30/27x48 |
|--------------------|---|-----------------|-----------------------|
| Designation | Type | - | low lift walkie |
| | Rated Capacity | lbs. | 3000 |
| | Load Center | in. | 24 |
| Chassis | Power | - | Battery |
| | Lowered Fork Height | in. | 3.3 |
| | Raised Fork Height | in. | 8 |
| | Body Height | in. | 27.2 |
| | Overall Body Length | in. | 64 |
| | Overall Body Width | in. | 28 |
| | Fork Length | in. | 48 |
| | Fork Width O.D. | in. | 27 |
| | Individual Fork Width | in. | 6.3 |
| | Fork Thickness | in. | 1.8 |
| | Service Weight w/o Battery | lbs. | 537 |
| | Battery Compartment | in. | N/A |
| Wheels | Drive Wheel Dia. x W / Qty | in. | 10 x 2.5 / x1 |
| | Load Wheel Dia. x W / Qty | in. | 2.9 x 3.9 / x2 single |
| | Stabilizer Dia. x W / Qty | in. | 3.9 x 1.6 / x2 |
| | Wheel Type - Drive | - | Polyurethane |
| | Wheel Type - Load | - | Polyurethane |
| Performance | Travel Speed - Loaded | mph | 2.9 |
| | Travel Speed - Unloaded | mph | 3.7 |
| | Lift Speed - Loaded | in./sec | 2.2 |
| | Lowering Speed - Loaded | in./sec | 2.2 |
| | Turning Radius | in. | 56.5 |
| | Minimum Aisle Width for 90 degree stack w/ 48" load | in. | 68 |
| | Gradeability - Loaded/Unloaded | % | 5 / 7 |
| | Drive Motor | HP | 0.8 |
| | Lift Motor | HP | 1.07 |
| | Control | - | Transistor, stepless |
| Brake | - | Electromagnetic | |
| Voltage / Amp Hour | V/AH | 24 / 60 | |

Performance may vary due to motor and system efficiency tolerances and represent nominal values under typical operating conditions.



85 Heart Lake Road South
 Brampton, Ontario, Canada L6W 3K2
 Phone: 905-457-3900 • Fax: 905-457-2313
 www.BlueGiant.com

AUTHORIZED DISTRIBUTOR

BLUE GIANT EQUIPMENT CORPORATION

BLUE GIANT offers a full line of Dock Levelers, Dock Safety Equipment, Accessories, Ergonomic and Scissor Lift Equipment and Industrial Trucks. Concurrent with our continuing product improvement program, specifications are subject to change without notice. Please contact BLUE GIANT for latest information. Some features illustrated may be optional in certain market areas.

If calling within North America: Phone: 1-800-668-7078 Fax: 1-888-378-5781

xpt30 Series, 11/15/06-0