

Designed with the operator in mind, the 24 volt BGS Series straddle stacker offers maximum safety and operator comfort for all intermediate duty pallet handling applications.

CAPACITIES

- BGS-15 - 1,500 lb at 24" load center
- BGS-22 - 2,200 lb at 24" load center
- BGS-30 - 3,000 lb at 24" load center

LIFT HEIGHTS

- 52, 72 inches
- 90, 110, 130, 150 inches

OPERATION/CONTROLS

- Ergonomic design with butterfly toward/reverse travel controls
- Large safety reversing button propels truck away from operator and sounds horn if contact with operator is made
- Automatic "dead man" type braking with power cut-off switch when brake is applied
- Heavy duty motor, gear pump, check and relief valve
- Lifting and lowering functions feature "soft start - soft stop" electro-hydraulic acceleration and deceleration valving
- Overload pressure relief valve protects system from pressure overload and bypasses oil to reservoir when system reaches maximum pressure
- Piston style lift cylinder includes micro finished surface and high quality polyurethane seals

DRIVE SYSTEM

- Smooth, stepless, adjustable travel speeds and acceleration rate with controlled plug braking
- Programmable controller for energy saving motor and battery operation allows battery efficiency and usage to increase by up to 50% over conventional resistor type
- Diagnostic test and fault information
- Totally sealed gear reducer / brake system with internal multi disc brakes in oil bath that virtually eliminates conventional brake safety problems such as adjustments, drum and/or shoe replacement
- All gear and brake components protected from exposure to moisture and dirt, packaging, strapping etc.
- All gears are precision ground helical gears and drive axle mounted on precision tapered roller bearings
- 210 AH hours rating, (qty 4 - 12 volt 105 AH hours rating, minimum maintenance deep cycle) with removable tray
- 115/1/60 15 amp onboard charger with overload protection direct wired to batteries for error free charging

ELECTRICAL SYSTEM

- 24 volt
- Key switch
- Fused drive and control circuits
- Series wound high torque maintenance free drive motor, Class H insulation and heavy duty motor contactors with replaceable tips
- Solid state programmable speed controller with solid state throttle mechanism
- Emergency power disconnect button



FORKS/CHASSIS

- BGS-22/30 mast of I-beam design (nested on telescopic models) with high quality ball bearing rollers and carriage side thrust rollers
- Twin double strand leaf-style lifting chain
- 36" long forged forks
- Adjustable straddles to 50" ID with guarded tips to protect wheels
- Safety screening protects operator from lifting mechanisms and provides maintenance free visibility

WHEELS

- Press-on 10" x 4" white, non-marking rubber, taper mounted hub design for easy servicing
- Poly straddle wheels 4" x 2" with precision sealed ball bearings

OPTIONAL EQUIPMENT

- Special application tires
- Other fork sizes
- Battery gauges
- U.L EE rating

Specifications

		BLUE GIANT			
CHARACTERISTICS	Manufacturer	(Abbreviation / Symbol)			
	Model	Manufacturer's designation			
	Capacity	Q	BGS-15	BGS-22	BGS-30
	Rated capacity	1,500 lb	2,200 lb	3,000 lb	
	Load center	C	Distance (Refer to charts)		
	Power type	Electrical			
	Control type	Hand, Pedestrian, Ride-On			
	Hand / Pedestrian	Hand / Pedestrian			
DIMENSIONS	Tire equipment	Drive end / Load end			
	Rubber / Poly	Rubber / Poly			
	Wheels	Number (x=driven) Drive end / Load end			
	1 x + 0 / 2	1 x + 0 / 2			
	Lift	H3 Lift	Refer to charts		
		Lift and fork height	Refer to charts		
	Forks	H2 Free lift	24"	12"	12"
		S Forks lowered	2"	2.5"	2.5"
		I Length standard	36"		
			Length optional	42", 48"	
		B3 Fork adjustment	8.5" - 27.25"		
		E Fork width x Thickness	4" x 1.5"		
	Overall dimensions	L Length	71.5"		
		B Straddle I.D. Standard / Optional	41" to 50" / 31" to 40"		
		H1 Minimum straddle I.D. setting	Refer to charts		
H4 Lowered mast height		Refer to charts			
H5 Raised mast height		Refer to charts			
Turning radius	WA	60.5"			
90° Stacking aisle	Refer to charts				
PERFORMANCE	Speeds	Traveling - with load	2.9 mph	2.6 mph	2.5 mph
		Traveling - without load	3.1 mph		
		Lifting - with load	22 fpm	16 fpm	15 fpm
		Lifting - without load	35 fpm	25 fpm	23 fpm
		Lowering - with load	42 fpm	37 fpm	36 fpm
		Lowering - without load	22 fpm	19 fpm	15 fpm
Grade clearance	8%				
LOAD	Dead weight	Including battery			
1,750 lb	1,750 lb				
Axle loading	Loaded - drive end	40%	33%	28%	
	Loaded - load end	60%	67%	72%	
CHASSIS	Tires	Quantity - Drive end / Load end	1 / 2		
		Dia. x width - Drive end	10" x 4"		
		Dia. x width - Load end	4" x 2"		
	Wheel base	Y	Distance between wheels		
	51.5"	51.5"			
	Ground clearance	1.25"			
Track	Center of tires				
Straddle I.D. + 3"	Straddle I.D. + 3"				
Service brake	Mechanical				
Parking brake	Automatic				
POWER / DRIVE UNIT	Battery	Type	Wet		
		Voltage / AH	24 / 170		
		Battery compartment L x W x H	28.6" x 9" x 24.6"		
	Electric motors	Drive motor	1 hp		
		Lift motor	5 hp		
Drive control	Type	Solid state			
	Stages forward / reverse	Variable			
Transmission	Type	Geared			

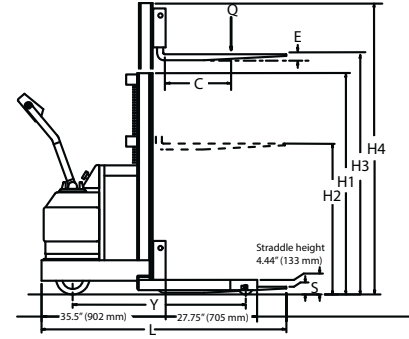

MAST SPECIFICATIONS

MODEL	LIFT	FREE LIFT	STAGES	MINIMUM STRADDLE I.D.	LOWERED MAST HEIGHT	RAISED MAST HEIGHT
—	H3	H2	—	H1	H4	H5
BGS-15	52"	52"	1	31"	72"	72"
BGS-22/30	52"	52"	1	31"	71.25"	71.25"
BGS-15	72"	72"	1	31"	92"	92"
BGS-22/30	72"	72"	1	31"	91.25"	91.25"
BGS-15	90"	23"	2	31"	72"	108.75"
BGS-22/30	90"	11"	2	31"	65.25"	109"
BGS-15	110"	23"	2	31"	82"	128.75"
BGS-22/30	110"	11"	2	31"	75.25"	129"
BGS-15	130"	23"	2	33"	92"	148.75"
BGS-22/30	130"	11"	2	33"	85.25"	149"
BGS-15	150"	23"	2	38"	102"	168.75"
BGS-22/30	150" *	11"	2	38"	95.25"	169"

* 3,000 lb model, downrated to 2,200 lb capacity above 130" lift

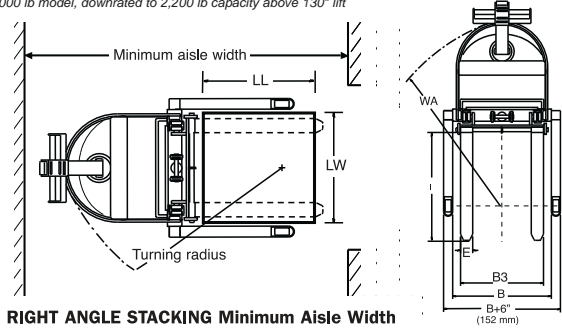

RIGHT ANGLE STACKING Minimum Aisle Width

1) If pallet bay opening is load width plus 10"

LOAD WIDTH (LW)	LOAD LENGTH (LL)			
	30"	36"	42"	48"
30"	72"	72"	72"	72"
36"	73"	73"	73"	73"
42"	75"	75"	75"	75"
48"	76"	76"	76"	76"

2) If pallet bay opening is load width plus 4" - 6"

30"	72"	77"	85"	93"
36"	73"	79"	87"	94"
42"	74"	80"	88"	95"
48"	76"	81"	89"	97"



65 Heart Lake Road South
Brampton, Ontario, Canada L6W 3K2
Phone: 905-457-3900 • Fax: 905-457-2313
www.BlueGiant.com

AUTHORIZED DISTRIBUTOR

BLUE GIANT EQUIPMENT CORPORATION

BLUE GIANT offers a full line of Loading Dock Equipment including Dock Levelers, Vehicle Restraints, Dock Seals and Shelters an improvement program, specifications are subject to change without notice. Please contact BLUE GIANT for latest information. Some

Material Handling Solutions. Concurrent with our continuing product e features illustrated may be optional in certain market areas.