



Conveyors and Accessories

LEWCO, Inc.'s conveyor product line includes a full range of high quality, heavy duty conveying products and accessories:

Powered Conveyors

- Chain Driven Live Roller
- Chain Conveyor
- Belt Driven Live Roller
- Belt Conveyors

Gravity Conveyors

- Gravity Roller
- Ball Transfer Tables
- Wheel Rail

In addition to LEWCO, Inc.'s pre-engineered standard conveyor line, LEWCO, Inc. provides custom solutions to specific application requirements. LEWCO, Inc. standard and custom solutions are designed and manufactured in our ISO 9001:2008 certified facility.

Applications

- Accumulation
- Washdown/Stainless
- Assembly
- Sortation Stacking/ Destacking
- Drum Handling
- Pallet Handling
- Package Handling
- Rack Storage
- Robotic Cell Delivery/ Assembly

Powered Conveyors

Chain Driven Live Roller

Roll to roll chain driven live roller conveyor provides a positive drive for handling heavier loads. Because of its rugged construction it can be used in wet, oily or contaminational applications. CLDR is available with LEWCO, Inc.'s 24-volt motor technology.



Belt Conveyors

Belt conveyors can be used in a variety of assembly, testing and sorting operations.

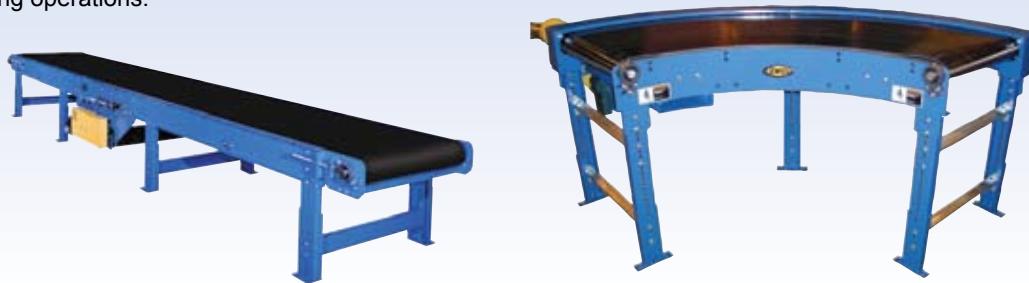

Chain Conveyors

LEWCO, Inc.'s multi-strand chain conveyor is a drag chain system for pallets with configurations not conveyable on roller conveyors. These low maintenance conveyors are suitable for extremely harsh applications. Chain conveyors are also available with 24-volt motor technology.

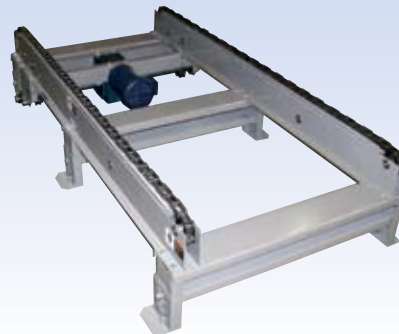

Belt Driven Live Roller Conveyors

Provide minimum pressure accumulation with rollers on close centers. Accumulation can be varied by adjusting tension rollers. BDLR is also available with LEWCO, Inc.'s 24-volt technology.



Gravity Conveyors

Gravity Roller Conveyors

Gravity Roller Conveyors are ideal for applications requiring an economical, non-powered means for conveying material. LEWCO, Inc. offers a broad range of light, medium and heavy duty models to accommodate any application. We offer standard models with 1.375", 1.9", 2.5", 2.562", and 3.5" rollers in lengths up to 120" and width between frames up to 51". A variety of paint options are available.



Ball Transfer Tables

Ball transfer tables are used to manually move loads in multiple directions. Ball transfers are 1" diameter zinc plated steel 1/4-20 with stud mounts. Transfers are rated at 50 pound capacity each.

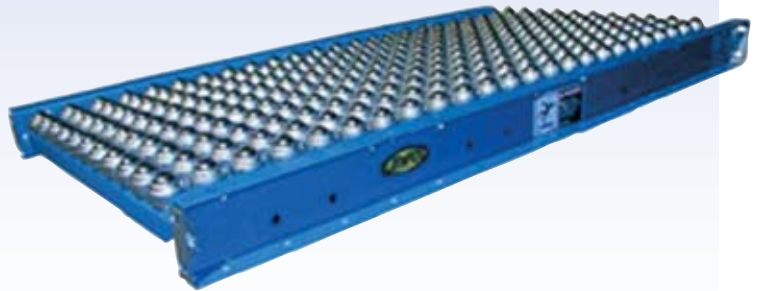

Turntables

Turntables can be used to provide convenient access to all sides of product being conveyed or as an intersection to two gravity lines to create a 90 degree turn.



Wheel Rail Conveyor

Wheel rails provide an economical means of conveying products in flow racks or other gravity applications. LEWCO, Inc.'s wheel rails use 75 pound capacity skate wheels in 12 gauge painted steel rails.

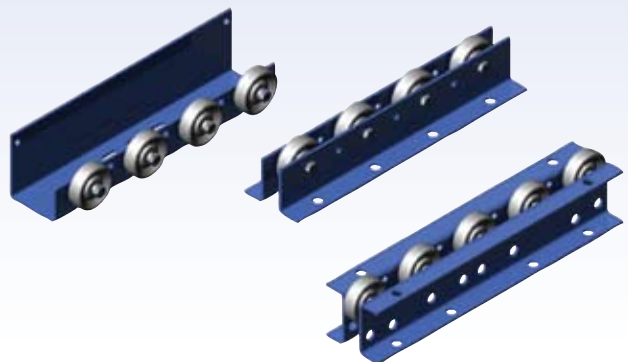

Transfer Cars

Transfer cars allow products to be removed from one lane to another parallel lane or conveyor.



Hinge Gates

Hinge gates provide convenient economical passageways for personnel or lift trucks and pallet jacks.



Slat Conveyors

Designed for long lasting service in heavy duty applications and can be modified for mounting assembly fixtures.



Conveyor Rollers

Replacement rollers are available in diameters from 1.375" to 3.5" and lengths from 6" to 81", including sprocketed rollers for chain driven conveyors.



Conveyor Supports

Supports come in a variety of sizes, styles and capacities. Height adjustment on standard models range from floor level supports to 208".

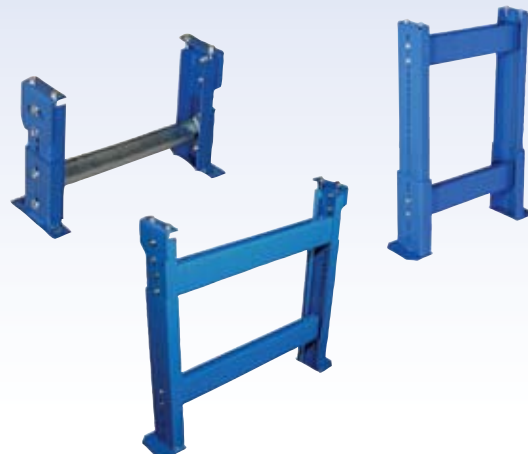

Custom Solutions

While LEWCO, Inc.'s pre-engineered conveyors are world class quality and competitively priced, LEWCO, Inc.'s strength is our ability to understand customers applications and design a solution best fitting the customer's needs at a competitive price. LEWCO, Inc. provides innovative industrial equipment custom solutions and designs to customers in a wide range of industries (both domestically and internationally) including warehouse and distribution, package handling, packaging, chemical, aerospace, defense, food and automotive.

All LEWCO, Inc. products are designed and manufactured under an ISO 9001:2008 quality system emphasizing customer focus and continuous improvement.

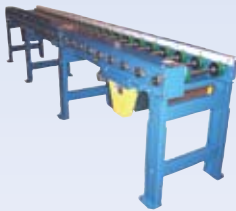

Accumulating Chain Driven
Live Roller Conveyor



Dual Chain Box Driven Live
Roller Conveyor with Fork
Pocket Cut Out

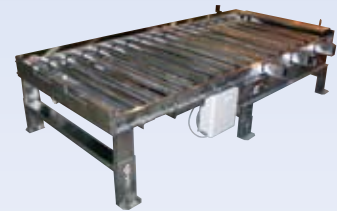

Stainless Steel CDLR with
Gravity Pop Up Roller Transfer



Escapement Stop

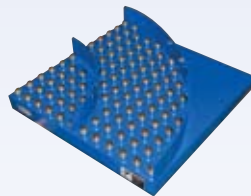

Dual Lane Ball Table Curve

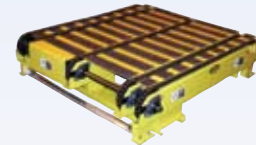

Multi-Strand Chain Conveyor
with Walkover Plates



Floor to Floor
Belt Conveyor



Pop-Up Pallet Jack
Feed Conveyor



Steel Hinged
Belt Conveyor

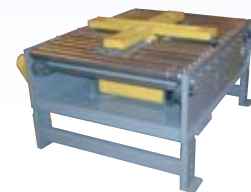

Pop-Up Pallet Rotator
with Chain Driven Live Roller

Process Heating Equipment Manufactured by LEWCO, Inc.

LEWCO, Inc. also manufactures a full line of industrial ovens. Offered in both batch and continuous configurations, LEWCO, Inc. has the unique ability to incorporate both our material handling and process heating technologies into a single seamless system for applications that require both.



Batch Process Ovens



Drum Heating Cabinet

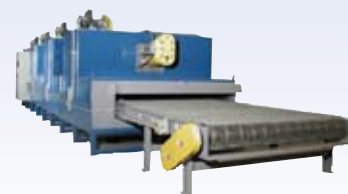

Continuous Process Ovens

Our Total Solution Approach

LEWCO, Inc. employs a six step approach to custom conveying solutions:

1. Initial Research and Analysis.

In this stage, LEWCO, Inc. will learn and analyze your current process to identify potential areas for improvement.

2. Concept Development. Our experienced applications team will develop the solution that most appropriately suits your needs.

3. Design. We select the latest technologies to integrate into the project. LEWCO, Inc.'s capabilities include both mechanical and electrical control design.

4. Manufacture. Our ISO 9001:2008 Certified factory and lean manufacturing allow us to handle any project no matter the size. LEWCO, Inc. is dedicated to manufacturing a quality conveying solution utilizing state-of-the-art production equipment to produce our products.

5. Installation. Our experienced field team performs turnkey installation at the customer's location.

6. After Sales Support. You have a constant partner with the project as LEWCO, Inc. provides continuous support and future updates as required.



706 Lane Street • Sandusky, OH 44870
Sales 419.625.4014 • Fax 419.625.1247
Email: sales@lewcoinc.com
www.lewcoinc.com